

C. 1.1

C. 1.1.1. This diagram shows the internal structure of a latrine. It illustrates the flow of waste from the toilet into a collection chamber, which is connected to a pit. The diagram also shows the location of the latrine superstructure, which is not shown in detail. The diagram is a cross-section, showing the internal components and their arrangement. The components include the toilet, the collection chamber, and the pit. The diagram is labeled with various letters and numbers, indicating different parts of the system. The diagram is a technical drawing, showing the internal structure of the latrine in a clear and concise manner.

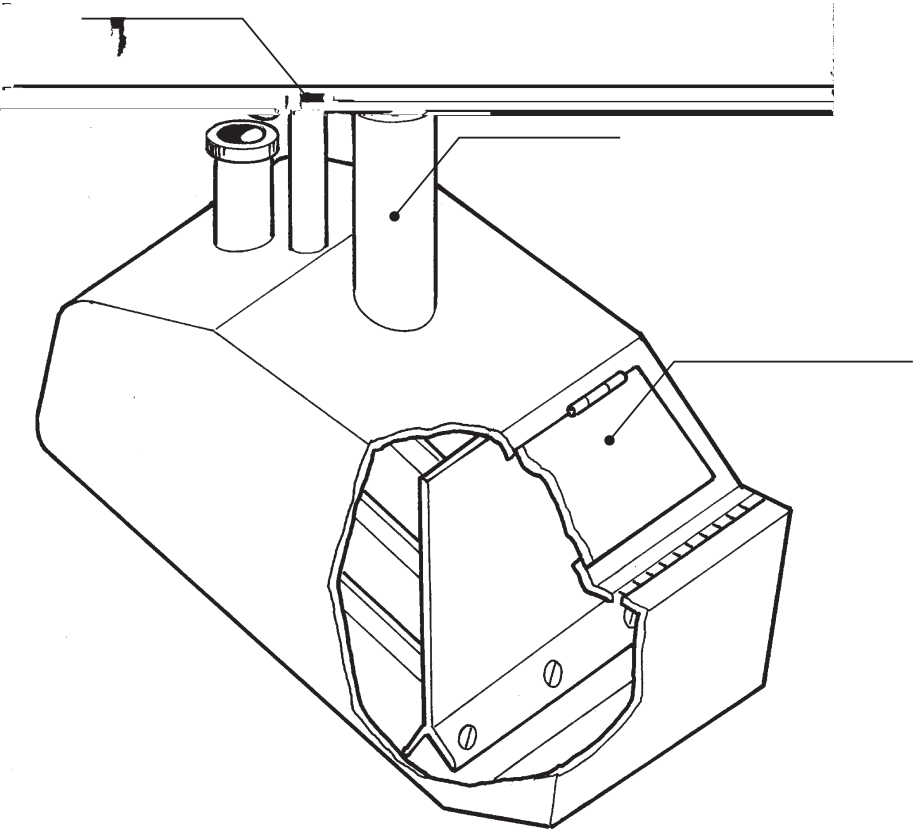
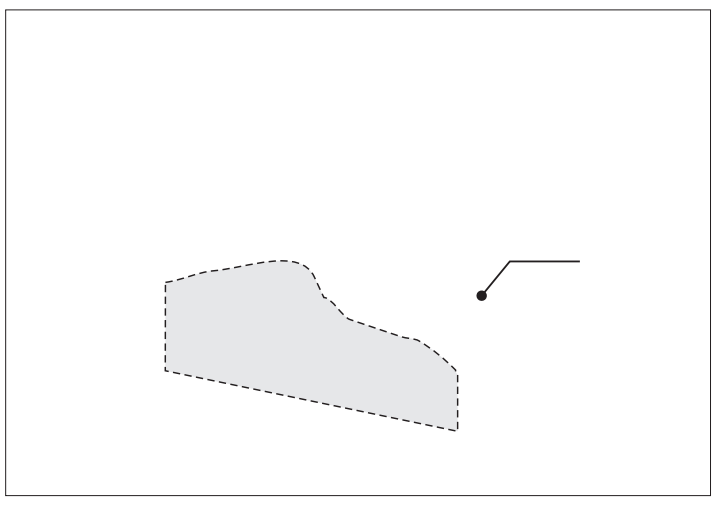

Figure 1. C. 1.1

(Latrine superstructure not shown)



B

... ..

F

... .. WHO, G ... 1992.
... .. ITP ... L ... 1995.

P B R R S